

British Board of Agrément

P O Box 195
Bucknalls Lane
Garston, Watford
Herts WD25 9BA
Tel: + 44 (0)1923 665300
Fax: + 44 (0)1923 665301
e-mail: mail@bba.star.co.uk
website: www.bbacerfs.co.uk

Electronic Copy

Authorised and notified according to Article 10 of the Council Directive (89/106/EEC) of 21 December 1988 on the approximation of laws, regulations and administrative provisions of Member States relating to construction products.



European Technical Approval ETA-07/0034

Trade name:

NUDURA Integrated Building Technology Insulated Concrete Form System

Holder of approval:

NUDURA Corporation
27 Hooper Road
Unit No 10
Barrie
Ontario
Canada L4N 9S3
Tel: + 1 705 726 9499
Fax: + 1 705 726 2110
e-mail: info@nudura.com
website: www.nudura.com

Generic type and use of construction product:

Insulating Concrete Formwork

Valid from: to:

7th March 2007
31st March 2012

Manufacturing plants:

Polymax, Inc
870 Industrial Boulevard
Granby
Quebec J2G 1A4
Canada

This European Technical Approval contains:

12 pages including two Annexes which form an integral part of the document



European Organisation for Technical Approvals

I LEGAL BASES AND GENERAL CONDITIONS

1 This European Technical Approval is issued by the British Board of Agrément in accordance with:

- Council Directive 89/106/EEC of 21 December 1988 [Construction Products Directive (CPD)] on the approximation of laws, regulations and administrative provisions of Member States relating to construction products⁽¹⁾, modified by the Council Directive 93/68/EEC of 22 July 1993⁽²⁾
- UK implementation of CPD Statutory Instruments 1991, No 1620. The Building and Building Construction Products Regulations 1991 — made 15 July 1991, laid before Parliament 22 July 1991, coming into force 27 December 1991, and amended by the Construction Products (Amendment) Regulations 1994 (Statutory Instruments 1994, No 3051)
- Common Procedural Rules for Requesting, Preparing and the Granting of European Technical Approvals set out in the Annex to Commission Decision 94/23/EC⁽³⁾
- Guideline for European Technical Approval of *Non-loadbearing permanent shuttering kits/systems based on hollow blocks or panels of insulating materials and sometimes concrete* ETAG 009, edition June 2002.

2 The British Board of Agrément is authorised to check whether the provisions of this European Technical Approval are met. Checking may take place in the manufacturing plant. Nevertheless, the responsibility for the conformity of the products to the European Technical Approval and for their fitness for the intended use remains with the holder of the European Technical Approval.

3 This European Technical Approval is not to be transferred to manufacturers or agents of manufacturers other than those indicated on page 1, or manufacturing plants other than those indicated on page 1 of this European Technical Approval.

4 This European Technical Approval may be withdrawn by the British Board of Agrément, in particular after information by the Commission on the basis of Article 5(1) of Council Directive 89/106/EEC.

5 Reproduction of this European Technical Approval, including transmission by electronic means, shall be in full. However, partial reproduction can be made with the written consent of the British Board of Agrément. In this case partial reproduction has to be designated as such. Texts and drawings of advertising brochures shall not contradict or misuse the European Technical Approval.

6 The European Technical Approval is issued by the approval body in its official language. This version should correspond to the version circulated within EOTA. Translations into other languages have to be designated as such.

(1) Official Journal of the European Communities No L40, 11.2.1989, p12.

(2) Official Journal of the European Communities No L220, 30.8.1993, p1.

(3) Official Journal of the European Communities No L17, 20.1.1994, p34.

II SPECIFIC CONDITIONS OF THE EUROPEAN TECHNICAL APPROVAL

1 Definition of product and intended use

1.1 Definition of the system

The NUDURA Integrated Building Technology Insulated Concrete Form System is formwork comprising factory assembled units, consisting of two expanded polystyrene (EPS) panels, each 67 mm thick, mechanically fixed together using an arrangement of hinged polypropylene webs moulded into each panel at production stage. Various forms are available within the range as described in this section allowing overall wall widths of 235 mm, 286 mm, 337 mm, 387 mm 438 mm to be formed. The components are:

- EPS forms — these are generally green in colour and are moulded from expanded polystyrene beads
- polypropylene spacers — these are black in colour and hinged at the internal face of EPS panels to allow ease of transporting to site. They are available in five sizes to give nominal concrete core widths of 100 mm, 150 mm, 200 mm, 250 mm and 300 mm. The spacer webs are designed with slots to receive horizontal reinforcement and the flanges, built into the EPS forms can be used to screw fix lightweight finishes such as plasterboard and weatherproofing systems subject to load limitations (see ETA holder's data sheets)

The upper and lower surfaces of the EPS forms incorporate small castellations so that adjoining forms effectively lock together without fixings. Forms can be used either way up (except brick ledge forms). The spacers run full height of the form and serve to hold the forms together and prevent the floats lifting during the concrete pour. The inner surfaces of the EPS panels feature vertical, dovetail grooves that allow full bonding with the concrete and provide locks for the end caps. The outer surfaces are lightly grooved vertically at 50 mm centres to aid cutting and trimming. The forms interlock and build up horizontally and vertically into a tight rigid formwork. The wall is formed by filling the forms with concrete. The formwork is used in conjunction with:

- concrete — typically grade C20 (to EN 206-1 : 2004) for plain walls or C25 to C37 for reinforced concrete depending on above or below ground use
- aggregate — a recommended maximum size of 10 mm to 13 mm aggregate used in concrete walls up to 150 mm nominal core thickness and 19 mm for 200 mm nominal core thickness and above. The concrete can contain an admixture complying with EN 934-2 : 2001 to allow placement by either rodding or free flow and allow adequate site time. Vibrating equipment can be used with care.

Components and finishes used in conjunction with the formwork, but not covered by this Certificate, are:

- steel reinforcement — where required, should comply with applicable national rules
- external render — either:
 - cement-based render of two or three coats of cement/sand/polymer rendering mix, with the basecoat reinforced with stainless steel or

galvanized expanded lath screw-fixed to the polypropylene flanges in the form, or

- acrylic-based render of two coats of proprietary rendering mix with glassfibre filament or nylon fibre mesh reinforcement within the basecoat applied directly to the surface of the EPS form
- external masonry — may be brickwork or stonework fixed in accordance with national regulations. The type of masonry unit shall be to the relevant part of EN 771 and, where masonry tests are required, they shall be to the relevant part(s) of EN 1052. Other external finishes can be applied subject to fixing requirements and load limitations
- internal finish — typically 12.5 mm thick plasterboard fixed directly to the polypropylene flanges with a plaster skim coat or taped joints. Other lining systems can be applied (such as vinyl, steel, wood and cement particle board) subject to load limitations
- brickwork/stonework wall ties to EN 845-1 : 2003
- trestle supports — supplied by the ETA holder.

1.2 Intended use

The system is for use in forming loadbearing and non-loadbearing internal or external walls. Once filled on site with concrete, the EPS formwork remains as a permanent part of the wall and so contributes to the overall thermal resistance of the completed wall construction. During the pouring and casting of the concrete infill, the formwork resists the pressure of wet concrete through the inherent strength and interlocking action of castellated horizontal joints and tying action of polypropylene spacers moulded into the EPS forms.

When using this type of construction below ground a waterproofing membrane, according to applicable national rules and compatible with the EPS, should be provided on the external surface. The membrane should be applied in accordance with the manufacturer's installation instructions and be protected from damage using an impact-resistant protective layer or sand blinding.

1.3 Intended life

The provisions made for the ICF elements in this ETA are based on an assumed working life for the system of at least 50 years. The indications given on the working life cannot be interpreted as a guarantee given by the manufacturer or approved body, but are to be used as a means for selecting the appropriate product in relation to the expected economically reasonable working life of the works.

2 Characteristics of product and methods of verification

2.1 Characteristics of product

The system's components are available in the range given in Table 1 of this ETA and have the characteristics listed in Annex 2.

The characteristic values and respective tolerances for the components of the system (see Annex 1, Figure 1) are stated in the manufacturer's Installation Manual.

The composition of the components of the system and the manufacturing and quality control procedures are deposited with the British Board of Agrément.

Table 1 Components

Description of element	Material
Standard form reversible	EPS
90° form reversible	EPS
45° form reversible	EPS
End cap with fastening strip	EPS
Long and short T-forms reversible	EPS
Height adjuster with fastening strip	EPS
Top form tapered one side	EPS
Top form tapered both sides	EPS
Single or double moulded brick ledge form unit	EPS
Brick ledge extension	EPS
Custom radius form unit	EPS
Spacer/webs, hinged	Polypropylene
Four-way web connector	Polypropylene

The ETA is issued for the system on the basis of the product composition held by the British Board of Agrément.

Changes to the components of the system or in the production process of the components, that could result in the details being held by the British Board of Agrément being incorrect, should be notified to the British Board of Agrément before the changes are introduced. The British Board of Agrément will decide whether the changes affect the ETA and consequently the validity of the CE Marking and whether further assessment and alterations to the ETA are required.

2.2 Methods of verification

2.2.1 The assessment of the fitness of the shuttering system for the intended use has been made in compliance with ETAG 009 *Guideline for European Technical Approval of non load-bearing permanent shuttering kits/systems based on shuttering elements or blocks of insulating materials and sometimes concrete* edition June 2002. The ETA is issued for the NUDURA ICF System shuttering kit on the basis of agreed information, deposited with the British Board of Agrément (BBA), which identifies the shuttering kit that has been assessed and evaluated. Changes to the production process of the kit or the components which could result in this deposited information being incorrect, shall be notified to the BBA before the changes are introduced. The BBA will decide whether or not such changes affect the ETA and consequently the validity of the CE Marking on the basis of the ETA and, if so, whether further assessment and/or alterations to the ETA shall be necessary.

2.2.2 Essential requirement 1 – Mechanical resistance and stability

2.2.2.1 Resulting structural pattern

In end use conditions walls made with NUDURA ICF System shuttering elements are walls of continuous type according to ETAG 009, paragraph 2.2.

2.2.2.2 Efficiency of filling

The requirements according to ETAG 009, section 5.1.2 are met through observation of the filling of a test panel with concrete and observation of filling technique. The efficient filling without bursting of the shuttering and without voids or any uncovered reinforcement in the concrete core is possible.

2.2.2.3 Resistance to filling pressure

The resistance to filling pressure has been determined by observation of the finished shuttering elements both during and on completion of filling. The requirements in respect of cracking and failure of the system elements and horizontal bowing of shuttering not exceeding 5 mm are also satisfactorily met.

2.2.2.4 Possibility of steel reinforcement

The instructions in the NUDURA ICF Installation Manual are appropriate to install steel reinforcement for walls according to EN 1992-1-1 : 2004 or corresponding national rules.

2.2.3 ER 2 Safety in case of fire

2.2.3.1 Reaction to fire

Euroclass F, No Performance Determined (NPD).

2.2.3.2 Resistance to fire

With the minimum thickness of the continuous concrete core for the 237 mm overall wall width being 101 mm the fire-resistance class of walls, with a minimum concrete strength C20 according to Table 1 of Annex C of ETAG 009 is REI 30. Similarly for the 286 mm overall wall width the continuous concrete core is 152 mm the fire-resistance class will be REI 120.

2.2.4 ER 3 Hygiene, health and the environment

2.2.4.1 Release of dangerous substances

According to the manufacturer's declaration the shuttering elements, taking account of the EU database 8, the NUDURA ICF System does not contain any dangerous substances.

2.2.4.2 Water vapour permeability

The tabulated design value of water vapour diffusion resistance coefficient of expanded polystyrene (EPS), according to EN 12524 : 2000, is $\mu + 60$. The values for the water vapour diffusion resistance of concrete depending on density and type are also tabulated in EN 12524 : 2000.

2.2.5 ER 4 Safety in use

2.2.5.1 Bond strength between the shuttering leaves and the concrete core.

The expanded concrete is effectively bonded to the concrete core by mechanical interlocking of the internal vertical dovetail slots and the concrete.

2.2.5.2 Resistance to filling pressure

The resistance to filling pressure has been determined by observation of lower sections of the shuttering leaves and is satisfactory for filling up to heights of approximately 4 m.

2.2.5.3 Safety against personal injury by contact

As delivered on site the shuttering elements do not have sharp or cutting edges. Because of the soft surface of the shuttering leaves there is no risk of abrasion or of cutting to people.

2.2.6 ER 5 Protection against noise

2.2.6.1 Airborne sound insulation

The NPD option in ETAG 009, Table 3, is used.

2.2.6.2 Sound absorption

The NPD option in ETAG 009, Table 3, is used.

2.2.7 ER 6 Energy economy and heat retention

2.2.7.1 For thermal resistance, the nominal value of the thermal resistance R of the 'the wall' elements, once filled with concrete, can be determined in accordance with EN ISO 6946 : 1996, EN 13163 : 2001 and EN 12524 : 2000. Once moulded and cured, the EPS has a nominal density of 20.5 kgm^{-3} with a nominal thermal conductivity of $0.037 \text{ Wm}^{-1}\text{K}^{-1}$.

2.2.7.2 The values of heat capacity of concrete and expanded polystyrene are tabulated in EN 12524 : 2000.

2.2.8 Aspects of durability and serviceability

2.2.8.1 Physical agent – no effect

2.2.8.2 Chemical agent – no effect

2.2.8.3 Biological agent – no effect

2.2.8.4 Resistance to normal use damage – generally, ducts should be incorporated in twin shuttering elements prior to concreting.

3 Evaluation of Conformity and CE Marking

3.1 Attestation of Conformity system

The system of attestation of conformity applied to this product shall be that laid down in the CPD, Annex III, 2(ii) (referred to as System 2+).

3.2 Responsibilities

3.2.1 Tasks for the manufacturer, Factory production control

The manufacturer continues to operate a factory production control system. All elements, requirements and provisions adopted by the manufacturer are documented. This ensures the product conforms with this ETA.

The manufacturer shall only use raw materials supplied with the relevant inspection documents as laid down in the prescribed test plan⁴⁾. The raw materials shall be subject to agreed controls and tests by the manufacturer before acceptance. Checks on incoming materials, such as polystyrene bead and solid polypropylene spacers, shall include control of the certificates of conformity presented by suppliers (comparison with nominal values) by verifying dimensions and determining material properties, eg chemical composition and physical properties.

The manufactured components are checked for dimensional compliance and visually for surface and other defects.

The frequency of controls and tests conducted during production and on the finished panel is laid down in the prescribed test plan, taking account of the manufacturing process.

The results of factory production control are recorded and evaluated. The records include at least:

- designation of the product
- type of control or testing
- date of manufacture of the product and dates of testing of the product or basic material and components

4) The prescribed test plan is deposited with the British Board of Agrément and is made available to the approved bodies involved in the conformity attestation process.

- result of control and testing and, if appropriate, comparison with requirements
- signature of person responsible for factory production control.

The records shall be presented to the inspection body involved in the continuous surveillance.

Details of the extent, nature and frequency of testing and controls to be performed within the factory production control shall correspond to the prescribed test plan included in the technical documentation of this ETA.

3.2.2 Tasks for approved bodies

3.2.2.1 Initial type-testing of the product

For initial type-testing⁽⁵⁾ the results of tests, assessments and calculations performed as part of the assessment for the European Technical Approval shall be used unless there are changes in the production line or plant. In such cases the necessary type-testing has to be agreed between the British Board of Agrément and the approved body involved.

3.2.2.2 Initial inspection of factory and of factory production control

The approved body shall ascertain that, in accordance with the prescribed test plan, the factory, in particular the staff and equipment, and the factory production control, are suitable to ensure a continuous and orderly manufacturing of the system components with the specifications given in part II, section 2 and the accompanying Annexes to this ETA.

3.2.2.3 Continuous surveillance

The approved body shall visit the factory at least once a year for routine inspections. It shall be verified that the system of factory production control and the specified manufacturing processes are maintained, taking account of the prescribed test plan.

The results of continuous surveillance shall be made available on demand from the approved body to the British Board of Agrément. Where the provisions of the European Technical Approval and the prescribed test plan are no longer fulfilled, the certificate of conformity shall be withdrawn by the certification body.

3.3 CE Marking

The CE Marking shall be affixed to the packaging of the panels. The CE symbol shall be accompanied by the following information:

- identification number of the notification body
- identification of the product
- name or identification mark of manufacturer
- the last two digits of the year in which the CE Marking was affixed
- number of the European Technical Approval
- number of the EC certificate of conformity.

(5) In the context of ETAG 009, initial type-testing may be by testing and/or by calculation.

4 Assumptions under which the fitness of the product for the intended use was favourably assessed

4.1 Manufacturing

NUDURA EPS Insulated Concrete Formwork is produced in a heat-moulded chamber where the dimensions, castellations and spacer positions are controlled by the template of the mould. The shuttering elements are manufactured in accordance with the ETA using the manufacturing processes as identified in the inspection of the plant by the British Board of Agrément and the approved body and laid down in the technical documentation. Tolerances for dimensional stability are maintained by curing the EPS forms for 48 hours in elevated-temperature ovens, in accordance with the agreed Quality Plan.

4.2 Packaging, transport and storage

The panels are wrapped in plastics bearing the manufacturer's name, product type, dimensions, quantity, date of fabrication and batch reference details.

In relation to transportation and storage, the panels should be treated as conventional insulation products.

4.3 Installation

4.3.1 Formwork

In accordance with the ETA holder's installation instructions. The formwork must be aligned using either the ETA holder's proprietary alignment system or a similar system approved by the ETA holder. These systems can be adjusted during the concrete pour to maintain the vertical alignment of the wall assembly.

4.3.2 Concreting

Ready-mixed concrete shall be to the relevant parts of EN 206-1 : 2004 with control according to Annex C of this Standard. Whenever possible, concrete shall be purchased under an approved scheme where there is continuous certification and testing of the supplier. Where such schemes/controls are not available it is the responsibility of the purchaser of the concrete to ensure fitness for purpose.

4.3.3 Criteria

The fitness for use of the system can be assumed if the panels are installed correctly in accordance with the following requirements:

- installation is carried out under the direction of personnel trained and qualified and verified as competent to install the product by the ETA holder or its agent
- installation is in accordance with the manufacturer's specifications and drawings prepared for that purpose, and the appropriate tools are used
- the specified panels and trestles are used.

4.4 Use, maintenance and repair

The assessment of the fitness for use is based on the assumption that maintenance is not required during the assumed intended working life.

Should repair prove necessary before concreting, replacement is advised. If required after concreting then cutting out and face replacement or foam spray repair is advisable.



On behalf of the British Board of Agrément

Date of issue: 7th March 2007



Chief Executive

ANNEX 1 PRODUCT RANGE

Figure 1 Standard component details (all dimensions in mm)

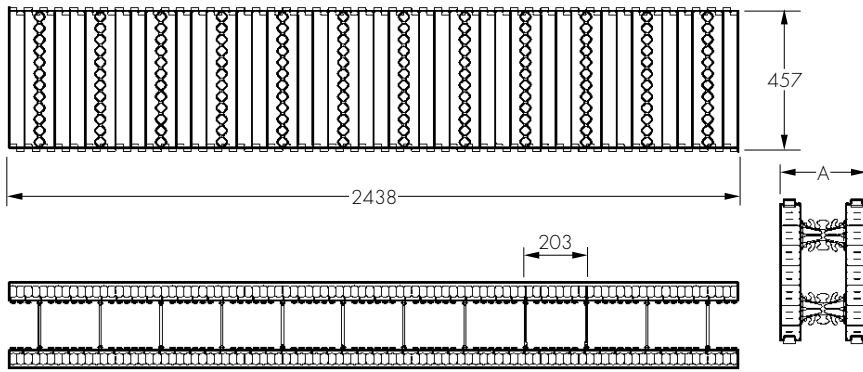

Nominal concrete core (mm)	Dimension A (mm)
100	235
152	286
203	337
254	387
305	438

standard form

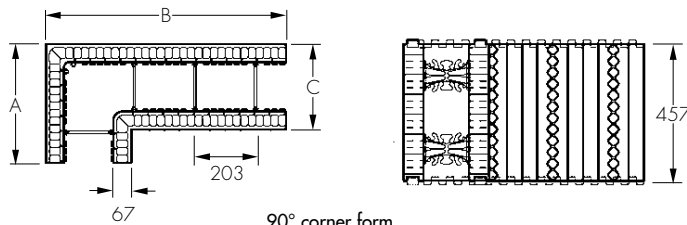

Nominal concrete core (mm)	Dimension (mm)		
	A	B	C
102	397	803	235
152	397	803	286
203	448	854	337
254	494	905	387
305	549	956	438

90° corner form

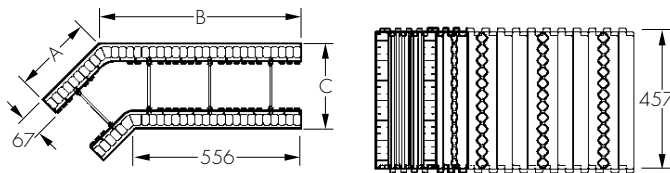

Nominal concrete core (mm)	Dimension (mm)		
	A	B	C
102	267	673	235
152	267	673	286
203	267	673	337
254	318	724	387
305	368	775	438

45° corner form

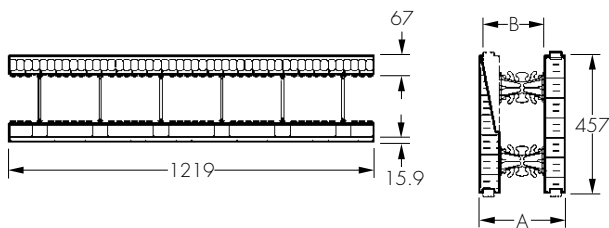

Nominal concrete core (mm)	Dimension (mm)	
	A	B
102	235	152
152	286	202
203	337	253
254	387	304
305	438	355

tapered top form (one sided)

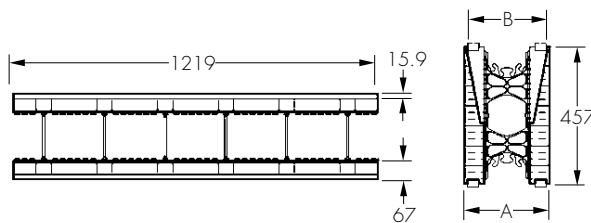

Nominal concrete core (mm)	Dimension (mm)	
	A	B
102	235	203
152	286	254
203	337	305
254	387	356
305	438	406

tapered top form (two sided)

Figure 1 Standard component details (continued) (all dimensions in mm)

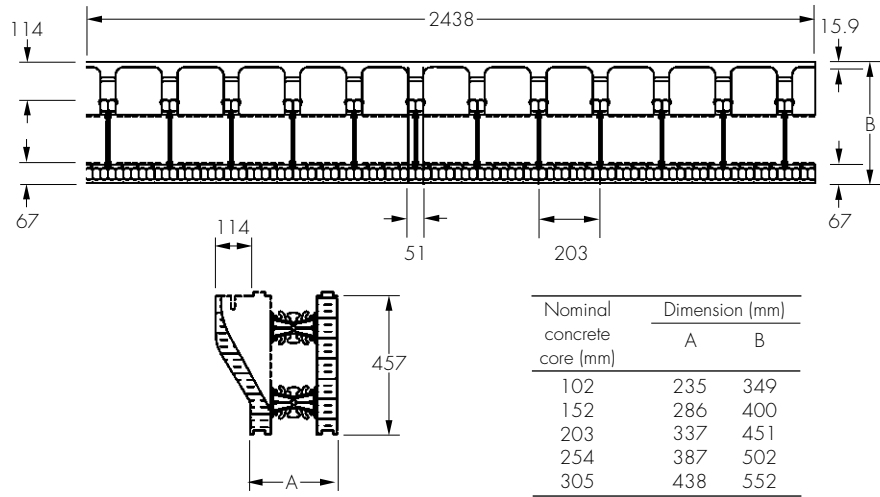

brick ledge form

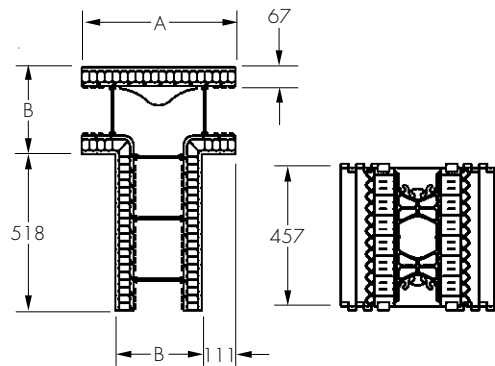

Nominal concrete core (mm)	Dimension (mm)	
	A	B
102	457	235
152	508	286
203	559	337
254	610	387
305	660	438

T-form (long) form

Nominal concrete core (mm)	Dimension (mm)	
	A	B
102	1270	235
152	1321	286
203	1372	337
254	1422	387
305	1473	438

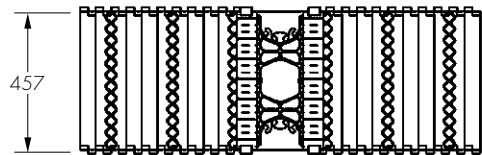

T-form (short) form

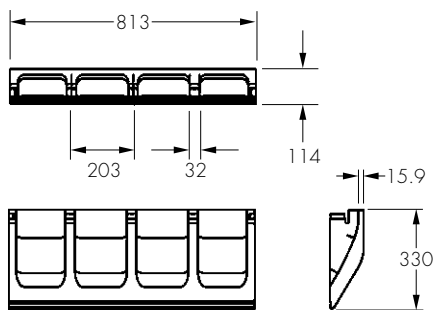

brick ledge extension

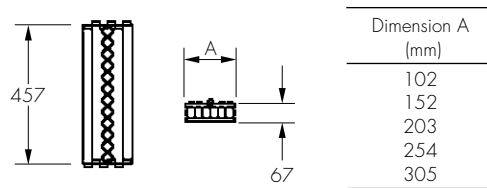

standard end cap with fastening strip

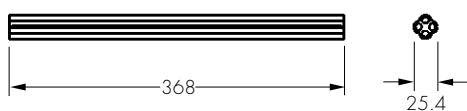

four-way web connector

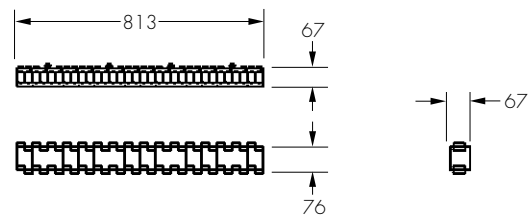

height adjuster with fastening strips

Figure 2 Typical construction details

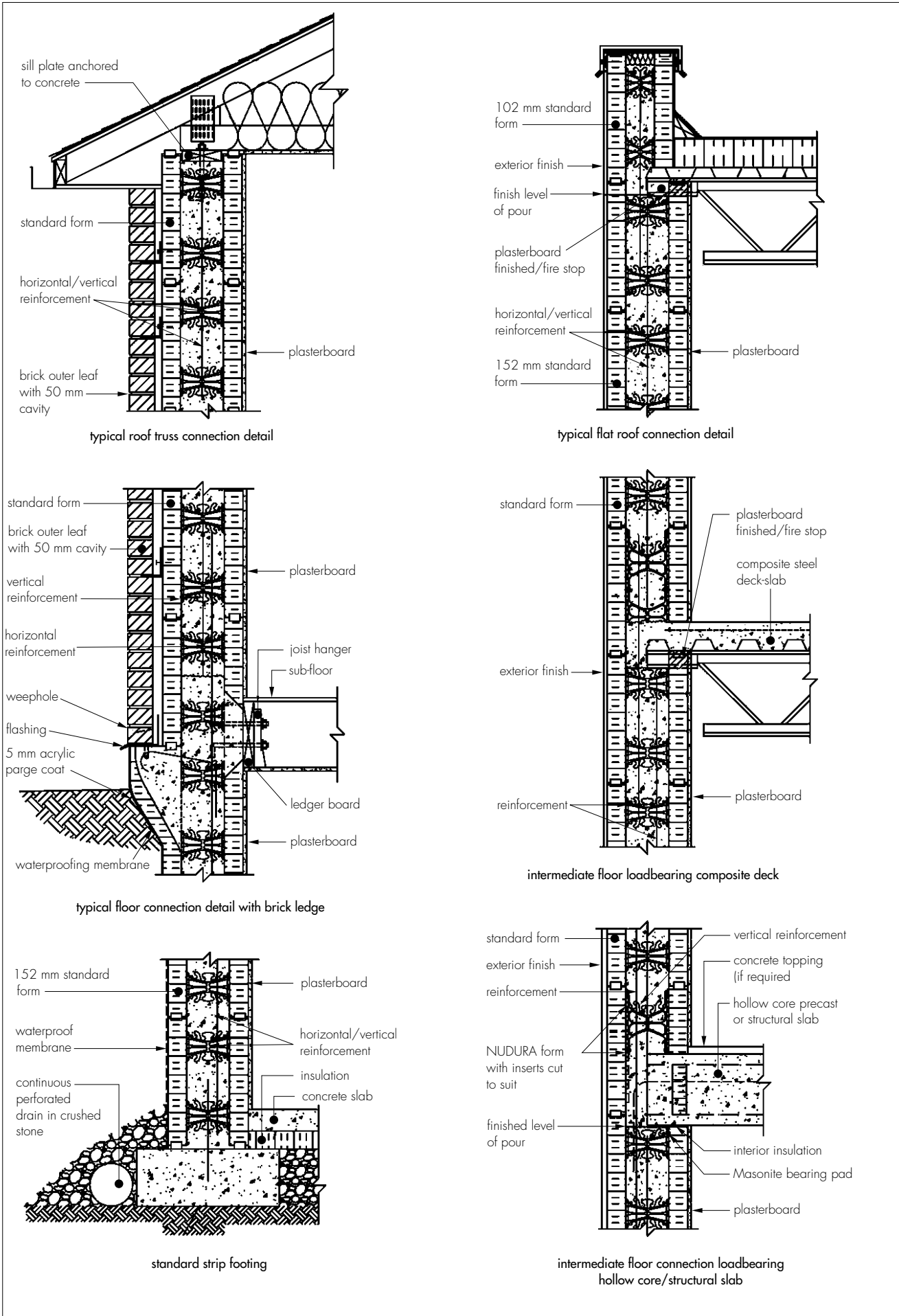

ANNEX 2 CONSTRUCTION DETAILS

Table 1 Product performance and characteristics

Property	Performance
Structural pattern	Continuous
Filling efficiency	Satisfactory
Steel reinforcement	Possible
Reaction to fire (Insulation)	Class E to EN 13501-1 : 2003
Dangerous substances	None
Water vapour permeability	A μ design value of 60 may be taken for the EPS
Filling pressure resistance	Slight joint leakage. Formwork needs verticality adjustment/checks during filling
Thermal properties	Using the following thermal conductivity (λ in $\text{Wm}^{-1}\text{K}^{-1}$) data $\lambda = 0.037$ <div style="text-align: right; margin-top: 5px;">Source of information BBA test data to EN 12667 : 2001</div>



©BBA 2007

British Board of Agrément

Bucknalls Lane, Garston, Watford, Hertfordshire WD25 9BA

Tel: + 44 (0) 1923 665300 Fax: + 44 (0) 1923 665301

e-mail: mail@bba.star.co.uk

website: www.bbacerts.co.uk